

---

## UNIT 7: COGENERATION

---

### Structure

- 7.0 Introduction
- 7.1 Introduction to Cogeneration
- 7.2 Need for Cogeneration
- 7.3 Principle of Cogeneration
- 7.4 Technical Options for Cogeneration
  - 7.4.1 Steam Turbine Cogeneration systems  
(Back Pressure Turbine and Extraction Condensing Turbine)
  - 7.4.2 Gas turbine Cogeneration Systems
  - 7.4.3 Reciprocating Engine Cogeneration Systems
- 7.5 Classification of Cogeneration Systems
  - 7.5.1 Topping Cycle
  - 7.5.2 Bottoming Cycle
- 7.6 Factors Influencing Cogeneration Choice
  - 7.6.1 Base electrical load matching
  - 7.6.2 Base Thermal Load Matching
  - 7.6.3 Electrical Load Matching
  - 7.6.4 Thermal Load Matching
- 7.7 Important Technical Parameters for Cogeneration
  - 7.7.1 Heat-to-power ratio
  - 7.7.2 Quality of Thermal Energy Needed
  - 7.7.3 Load Patterns
  - 7.7.4 Fuels Available
  - 7.7.5 System Reliability
  - 7.7.6 Grid Dependent System Versus Independent System
  - 7.7.7 Retrofit Versus New Installation
  - 7.7.8 Electricity Buy-Back
  - 7.7.9 Local Environmental Norm/Regulation
- 7.8 Prime Movers for Cogeneration
  - 7.8.1 Steam Turbine (Back Pressure turbine, Extraction Condensing turbine)
  - 7.8.2 Gas Turbine (Gas Turbine Efficiency, Net Turbine Efficiency)
  - 7.8.3 Reciprocating Engine Systems
- 7.9 Typical Cogeneration Performance Parameters
- 7.10 Benefits/Relative Merits of Combined Cycle, Cogen and CHP Technology Systems
- 7.11 Energy Performance Assessment of Cogeneration
- 7.12 Case Study: Applications of Small Cogeneration Plant (in Distillery, Sugar and Cement industry)
- 7.13 Let Us Sum Up
- 7.14 Glossary
- 7.15 Answer to Check Your Progress
- 7.16 References and Further Readings

---

## 7.0 INTRODUCTION

---

Cogeneration is broadly defined as the coincident or simultaneous generation of Combined Heat and Power (CHP). In a true cogeneration system a “significant” portion of the generated or recovered heat must be used in a thermal process as steam, hot air, hot water (HW), etc. There are two fundamental types of cogeneration (or in-plant power from Cogeneration -  $E_{CHP}$ ) systems, viz., topping and bottoming cycles, differentiated on the basis of whether electrical or thermal energy is produced first. Co-generations uses waste heat (WH) for many different

industrial processes, such as heating or drying or melting or baking. CHP plants are typically embedded close to the end user and therefore help reduce transportation and distribution losses, improving the overall performance of the electricity transmission and distribution network. Industrial WH is the energy that is generated due to fuel combustion or chemical reaction in industrial processes which is not put into any practical use and is normally wasted or dumped, released into the environment, even though it may still be reused. Cogeneration is used in several different industries, from chemical plants and industrial facilities to hotels, to boost their financial performance and lessen their environmental impact.

Energy is the driving force and foundation of national economic development, and is closely related to people's daily life. Fast depletion of coal reserves and ever increasing oil & gas (O&G) prices are resulting in the increased unit costs of generated electrical power which necessitate the system designer to select a process or a system with maximum heat recovery ( $HR_{\max}$ ) for plant economics. Cogen power plants use waste heat for many different processes, whereas the Combined-cycle power generation is a two-cycle electricity generation process that uses the heat from the first cycle to run a second cycle. The cogenerated power is typically in the form of mechanical or electrical energy. The more efficient use of process heat represents one of the main areas where industry and commerce can make long lasting, effective savings of energy and cost reduction. The purpose of this Unit 7 is to provide a brief understanding of the various Cogeneration technologies and techniques that may be used to achieve the maximum efficiency ( $\eta_{\max}$ ) in fuel utilization and power generation.

To this end, various CHP practices are compiled in the document and analyzed for their implementation benefits and constraints. Accordingly, the scope of this text, it includes a comprehensive review of various applicable Cogen methods, technologies/techniques for the industries and guidelines for implementing the selected method or technology.

This text discusses selection, practical issues in common cogeneration systems. References are highlighted and Case Study (Applications of Small Cogen) discussed in Chapter 7 to give little more insight into the systems of Cogen exist in core sectors.

### **Objectives**

After studying this unit, students should be able to:

- Conceptualize the key concepts related to analysis for Cogeneration, including the exhaust gases reference quality in the environment, its effective heat transfer condition, maximum power generation and losses in energy transformation.
- Organize the data, evaluate a qualification and feasibility analysis for the development of a Cogen (CHP) system (new or existing installation) which includes understanding whether the facility is a good candidate for a CHP system, analyzing potential barriers, estimating technical and economic opportunities, and need of optimizing a CHP system design.
- Information presented is meant to help students (may include users at site) to understand the potential benefits derived from implementing a CHP project and recognize opportunities for successful application of Cogen technology.

- Descriptions of prime movers commonly used in CHP applications, including discussions about design characteristics, heat-recovery (HR) options, equipment, fuels, emissions, efficiency, maintenance, availability and capital cost.
- From an engineering viewpoint, application of Cogen technology (matter of cycle selection, design of piping & valving arrangements), and not of basic differences in boilers, turbines, heat exchangers, and electrical generators.
- Understand the potential uses of generated power from CHP and steps for evaluating the technical feasibility of applying Cogen technology.
- Understand the CHP system's sufficient capacity to satisfy the critical electrical needs of the facility loads.
- Define these factors (which influence the size of CHP system) and evaluate economic feasibility (using appropriate data) and availability.

---

## 7.1 INTRODUCTION TO COGENERATION

---

With the growing trend of increases in fuel prices over the past decades as well the rising concern regarding global warming, climate change, engineering, petroleum oil refining, natural gas (NG) processing, process plants and power generating industries are challenged with the task of reducing greenhouse gas (GHG) emissions and improving the efficiency of their sites. The equivalent attention should be given to procuring lowest cost raw materials, waste minimization, fuel utilization as not only does overall economy and effective fuel utilization to achieve the direct savings of money, but also it must be realized that fuel wasted is total (monetary & energy) loss, not only to the user, but also to the nation. The use of fossil fuels to create electricity is not doing great things for our planet, and we needed to create alternative ways in which to generate energy that weren't so detrimental.

Energy is the primary resource for developing and sustaining the economy of a country, and the percentage in growth of energy demand is very closely linked to the percentage of GDP growth. On 27-7-2022, our Union Power and New & Renewable Energy Minister Mr. R.K. Singh said the country's electricity generation capacity will reach 820 GW by 2030, including more than 500 GW from non-fossil fuel sources. To deliver a sustained growth of 8% through 2031, India would need to increase its primary energy supply by 3-4 times, and electricity by 5-7 times of the present consumption. (NITI Aayog/erstwhile Planning Commission of India 2005).

Minimising energy demand growth through improvements in energy efficiency (EE) makes a critical contribution in the Net Zero Emission (NZE). Many efficiency measures in industry, buildings, appliances and transport can be put into effect and scaled up very quickly. As a result, EE measures are front-loaded in the NZE, and they play their largest role in curbing energy demand and emissions in the period to 2030. Although EE improves further after 2030, its contribution to overall emissions reductions falls as other mitigation measures play an expanding role. Without the EE, behavioural changes and electrification measures deployed in the NZE, final global energy consumption (International Energy Agency, NZE report, Oct. 2021) would be around 300 EJ higher in 2050, almost 90% above the

2050 level in the NZE. Efficiency improvements also help reduce the vulnerability of businesses and consumers to potential disruptions to electricity supplies.

An energy supply system that uses fossil fuel to produce electricity and then recovers WH from the combustion process for heating or other productive uses is known as Combined Heat and Power (CHP) or Cogen. A process which falls within this category is that of CHP - a high-efficiency system that produces both electricity and usable heat simultaneously. By definition, the Cogeneration or CHP is the use of a single energy source to produce two forms of energy - electricity and thermal energy ( $E_{th}/heat$ ). Broadly, CHP is on-site generation and utilization of energy in different forms simultaneously by utilizing fuel energy at optimum efficiency ( $\eta_{optm}$ ) in a cost-effective and environmentally responsible way. Heat produced by burning fuel, which often is released into the atmosphere, can be recaptured to either warm a process fluid or drive a turbine to make electricity. WHR (from hot fluid stream)-to-energy plants, which burn fuels such as municipal, industrial, biomass and agricultural waste, may generate electricity or may cogenerate if they produce both electricity and thermal energy. Cogeneration does not refer to the operation of two generating sources working in parallel; such as two generators linked together as a one-unit source of power.

Indian power sector had brought out important changes, among others, open access to the transmission system of the State grid on payment of mutually agreed wheeling charges for facilitating new entrants in the power sector on the captive power/co-generation route in restructuring process of the electricity sector at least a decade before (after 9<sup>th</sup> October, 1995 circular on “Policy for Captive and Co-Generation Plants” by the Ministry of Power). Similar restructuring policy decisions in the electricity sector have also been taken in many developing countries, many implemented and few are in progress.

A well known utility company may sell energy in two forms: electricity and steam. One thousand kJ of steam energy would cost about half as much as one thousand kJ of electrical energy. How does this company, and many others just like it would justify and manage such a mismatch of cost (per unit output/product) for the same thing? Cost analysis holds a distant second place or is frequently ignored in everyday experiences and cost analysis goes beyond the actual monetary value of energy for it affects the rate of depletion of finite energy reserves, the production of carbon dioxide ( $CO_2$ ) resulting from fossil fuel combustion, and the overall impact of energy on the environment.

The traditional method of supplying energy to a site uses both grid-supplied electricity and a separate fuel source for thermal demands as shown in **Figure 7.1.1**.

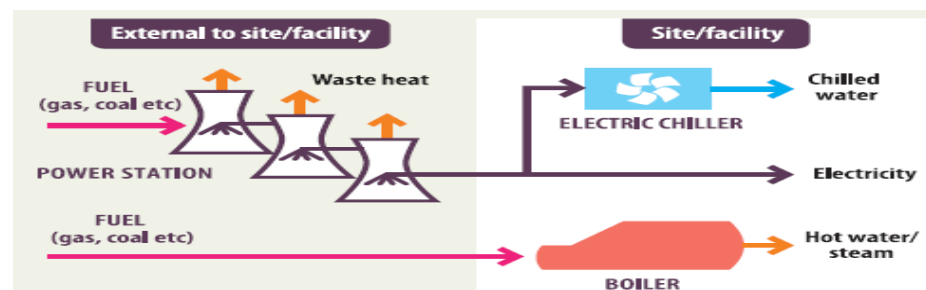

**Figure 7.1.1:** Traditional generation for heating

In a Cogen system, energy is supplied with a single fuel source and WH is captured and utilized (Figure 7.1.2). As a result, cogeneration can generate substantial savings for the end user.

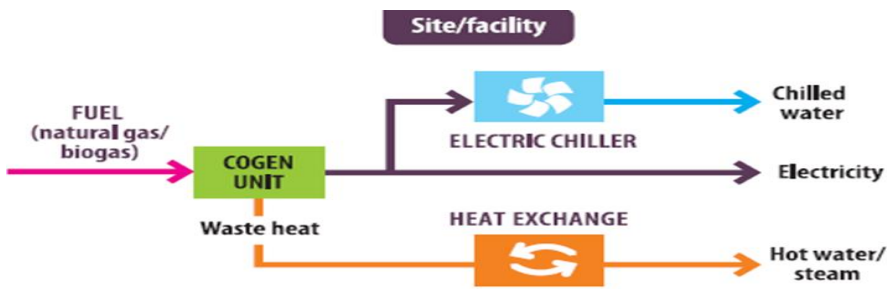

**Figure 7.1.2:** Cogeneration system

The power from CHP may be totally used in the industrial plant that serves as the “host” of the cogeneration system, or may be partially/totally exported to a utility grid. CHP is defined as the sequential generation of two different forms of useful energy from a single primary energy source. Mechanical energy may be used either for driving an alternator for producing electricity or rotating equipment such as motor, compressor, pump or fan for delivering various services.  $E_{th}$  can be used either for direct process applications or for indirectly producing steam, hot water (HW), hot air for dryer or chilled water for process cooling.

This chapter presents an overview of current status on design, analysis and evaluation guidelines. In this regard, the use of CHP systems in industrial processes/systems has been the key as one of the major areas of research, formulation of project/scheme and implementation to reduce fuel consumption, lower harmful emissions and improve production/generation efficiency. The recovery of industrial WH for power is a largely untapped type of CHP, which is the use of a single fuel source to generate both thermal energy and electricity.

## 7.2 NEED FOR COGENERATION

Notice that, if a heat engine were perfectly designed, its necessary heat rejection to the environment (sink) would be so close to the ambient temperature ( $T_a$ ) that it would have no useful energy (i.e. no exergy). Conversely, if a heating device were perfectly designed, its maximum temperature ( $T_{max}$ ) would be just above the desired utilization level. However, actual heat engines release waste heat at about  $\sim 127^\circ\text{C}$  ( $400^\circ\text{K}$ ) over  $T_a$ , and boilers may use flames at  $1727^\circ\text{C}$  ( $2000^\circ\text{K}$ ) to heat water to  $127^\circ\text{C}$  ( $400^\circ\text{K}$ ). This practical poor design of either single (work or heat) producer is what justifies the interest in combined their production, although the saving in required components may be another advantage.

Cogen, also known as CHP, is defined as the combined/simultaneous/sequential production/generation of two [work & heat (net actual useful heat)] or multiple forms of energy from a single primary energy/fuel source.

1. Thermal (heat) and electrical (electricity) are usually the two forms of energy produced in many types of cogeneration applications.
2. Cogen systems are of several types and almost all types primarily generate electricity along with making the best practical use of the heat, which is an inevitable by-product.

3. Cogeneration helps to improve the efficiency of the plant.
4. Cogeneration reduces air emissions of particulate matter, nitrous oxides (N<sub>2</sub>O), sulphur dioxide (SO<sub>2</sub>), mercury and CO<sub>2</sub> which would otherwise leads to greenhouse effect.
5. It reduces cost of production and improves productivity.
6. Cogeneration system helps to save water consumption and water costs.
7. Cogen system is more economical as compared to conventional power plant.

During conventional separate power and heat generation, nearly 2/3<sup>rd</sup> of energy is wasted - discharged to the atmosphere as heat during generation, transmission, and distribution.

Alternatively, the traditional systems for generating electricity have an average efficiency ( $\eta_{avg}$ ) of 35-40% (as high as 55% for combined-cycle systems), releasing 60-65% of the energy content of their fuel into the environment. CHP reclaims this heat loss ( $H_L$ ) and applies it to heating or cooling needs. Heating includes the production of steam and hot water (HW). Cooling requires the use of absorption chillers that transform heat into cold. By capturing and using heat that would otherwise be wasted and by avoiding distribution losses, CHP can achieve efficiency of over 80%, compared to 50% for typical technologies (e.g., conventional electricity generation & an on-site boiler). Thus, by simultaneously generating electricity and heat, Cogen units have a higher overall efficiency ( $\eta_{ov}$ ) that may reach up to 90% max. Because of this increased efficiency along with the saving of fossil fuels, CHP systems can allow reducing the emission of GHGs (particularly CO<sub>2</sub> emission per unit of useful energy output) than separate heat and grid power. Cogen is a highly efficient form of energy conversion and it can achieve primary energy savings of approximately 40% by compared to the electricity (from separate thermal power plants or purchase from state/national electricity grid) and heat production (using steam boilers) for onsite heating.

### 7.3 PRINCIPLE OF COGENERATION

Cogeneration is having one of the leading technological advancements for achieving fuel efficiency. **Figure 7.3.1** shows the Schematic Diagrams of Generation of heat and electricity with Cogeneration.

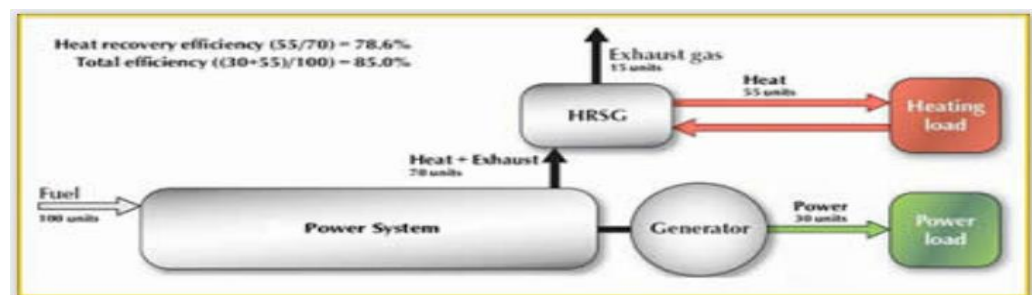

**Figure 7.3.1:** Generation of heat and electricity with Cogeneration

(Source: RETScreen International, clean energy projects analysis - Cogeneration project)

In a Cogeneration or CHP configuration, there are two different (distinct) cycles: topping cycle and bottoming cycle. In a topping cycle system electricity is the primary product and the residual WH is the primary mover for application. In other words, topping cycle plants produce electricity from a steam turbine with WH being the byproduct. During a bottoming cycle, the steam (high heat) is created first and then an WHR boiler used to feed to provide power for an industrial processes, such as a steam turbine, (primary product) with the lower pressure (LP) exhaust steam used to create electricity (primary mover). Bottoming cycle plants are only used when the industrial process requires very high temperatures (HTs), such as furnaces for glass and metal manufacturing, hence it's rare. Bottoming cycle plants are less common throughout the world due to the HTs required.

The detailed examination, analysis of the heat usage of any industrial and process that are unavoidable and irrecoverable or unaccounted, (c) the  $H_{L_s}$  that can be avoided or reduced and (d) the  $H_{L_s}$  that can be economically recovered. It is essential that at least approximate data relating to the above sub-divisions is collected so that an understanding of the heat balance of the process or system is obtained. This will reveal whether it is possible or worthwhile to either modify the process or system to reduce energy use, or alternatively, incorporate some form of HR technique. CHP plants are not new.

---

## 7.4 TECHNICAL OPTIONS FOR COGENERATION

---

Cogeneration or CHP is a thermo dynamically efficient use of fuel. It is not new. The most prevalent example of Cogen or CHP is the generation of electric power and heat. Cogeneration is a proven technology that can be applied in many sectors that using large energy such as in engineering, petroleum oil refining, NG processing, industrial process plants and power generating industries/plants. Cogen or CHP is the use of a heat engine or power station to simultaneously generate electricity and useful heat. The heat may be used for generating steam, hot water, or for cooling through absorption chillers. In a broad sense, the system, that produces useful energy in several forms by utilizing the energy in the fuel such that  $\eta_{ov}$  of the system is very high, can be classified as Cogeneration/CHP System or as a Total Energy System.

In general, cogeneration can be considered when:

- demands for heat and power are concurrent;
- heat demand (on-site and/or off-site), in terms of quantity (operating times during year), temperature, etc. can be met using heat from the CHP plant, and no significant heat demand reductions can be expected.

In separate production of electricity, some energy must be discarded as WH, but in Cogen this thermal energy is put to use. All thermal power plants exhausts heat during electricity generation, which can be released into the natural environment through cooling towers, flue gas, or by other means. By Cogen system, this WH is captured to produce hot water, steam, or chilled water.

The concept is very simple to understand as can be seen from following points.

- Conventional utility power plants utilize the high potential energy content (chemical energy) available in the fuels at the end of combustion process (HT kinetic energy) to generate electric power. However, the substantial

portion of the low-end residual energy goes to waste by rejection to cooling tower and in the form of HT flue gases.

- On the other hand, a cogeneration process utilizes first the high-end potential energy to generate electric power and then feasibly (on working out techno-economics) utilizes on the low-end residual energy to work for heating process, equipment or such similar use.

Consider the following example in the scheme referred in **Figure 7.4**. An industrial plant requires 24 units of electrical energy and 34 units of steam for its processes. Through separate heat and power route the primary energy input in power plant will be 60 units ( $24/0.40$ ), where plant's maximum efficiency 40%. If a separate boiler is used for steam generation then the fuel input to boiler will be 40 units ( $34/0.85$ ), where boiler's maximum efficiency 85%. Total fuel input needed is 100 units. Refer **Figure 7.4.1** (top).

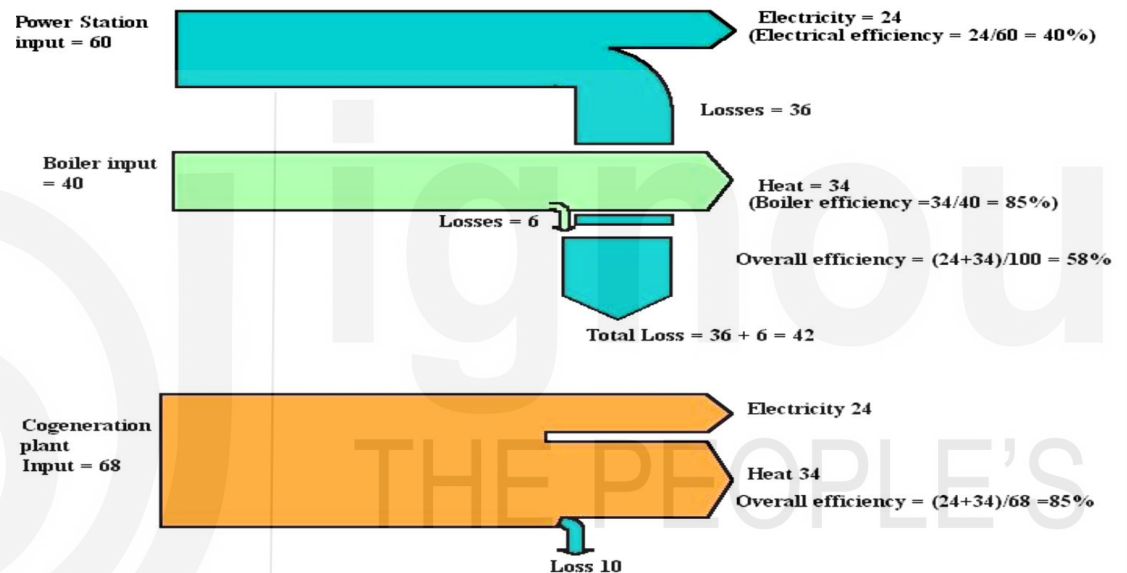

**Figure 7.4.1:** Cogeneration (Bottom) compared with conventional generation (top)

If the same end use of 24 units of electricity and 34 units of heat, by opting for the cogeneration route, as in **Figure 7.4.1** (bottom), fuel input requirement would be only 68 units  $[(24 + 34)/0.85]$ , where Cogen's maximum efficiency 85% compared to 100 units with conventional generation to meet both electrical and thermal energy requirements. It can be observed that the losses, which were 42 units  $[100 - (24+34) = 42 \text{ units}]$  in the case of, separate heat and power, which has reduced to 10 units  $[68 - (24+34) = 10 \text{ units}]$  in cogeneration mode. So, the cogeneration mode is advantageous than conventional one. For the industries in need of energy in different forms such as electricity and steam, (most widely used form of heat energy/ $E_{th}$ ), the cogeneration is the right solution due to its viability from technical, economical as well as environmental angle.

Under the right circumstances, power generation systems can also achieve 50-200% gains in efficiency or more over some of their current setup. Increasing concern about carbon dioxide ( $CO_2$ ) emissions makes reduced use of fossil fuels urgent for the future. Instead of a complete change in power production technology (hydroelectric, solar, wind) companies are gaining efficiency much more cheaply through cogeneration. CHP is as likely to depend as much on economic conditions as EE optimization. CHP opportunities should be sought on the identification of possibilities, on investment either on the generator's side or potential customer's

side, identification of potential partners or by changes in economic circumstances (heat, fuel prices, etc.).

Cogen provides a wide range of technologies for application in various domains of economic activities. The overall efficiency ( $\eta_{ov}$ ) of energy use in CHP mode can be up to 85% and above in some cases.

### **Main components and characteristics of a cogeneration (CHP) system**

CHP systems consist of a number of individual components - prime mover (heat engine), generator, heat recovery (HR), and electrical interconnection - configured into an integrated whole. A Cogen facility consists of following four main components:

1. Prime mover, generally a turbine or a combustion thermal engine (Rankine, Brayton, Diesel, Otto, Stirling) or a turbine/combination of thermal engines which converts chemical energy of fuel into mechanical energy transmitted to electrical generator;
2. Electric generator powered by the prime mover;
3. New heat recovery boiler to produce steam from the energy contained in the exhaust gas of the turbine or combustion engine. Energy recovery can be maximized by installing a standard economizer at the outlet of the HR boiler (temperature of the combustion gas, which ranges from 120°C to 150°C, depending on the fuel, can also be reduced). If the process requires a significant volume of hot water, a condensing economizer can follow, or replace, the economizer (temperature of the combustion gas can then be lowered to 50°C or 60°C); and
4. Control system.

These prime movers are capable of burning a variety of fuels, including NG, coal, oil, and alternative fuels to produce shaft power or mechanical energy.

#### **7.4.1 Steam Turbine (ST) Cogeneration systems**

##### **(Back Pressure Turbine and Extraction Condensing Turbine)**

The two types of steam turbines most widely used are the backpressure and the extraction-condensing. Another variation of the ST topping cycle CHP system is the extraction-back pressure turbine that can be employed where the end-user needs thermal energy ( $E_{th}$ ) at two different temperature levels. The full-condensing steam turbines are usually incorporated at sites where heat rejected from the process is used to generate power.

**Figure 7.4.2** shows the Schematic Diagrams [(i) & (ii)] of Steam Turbine Cogeneration Systems.

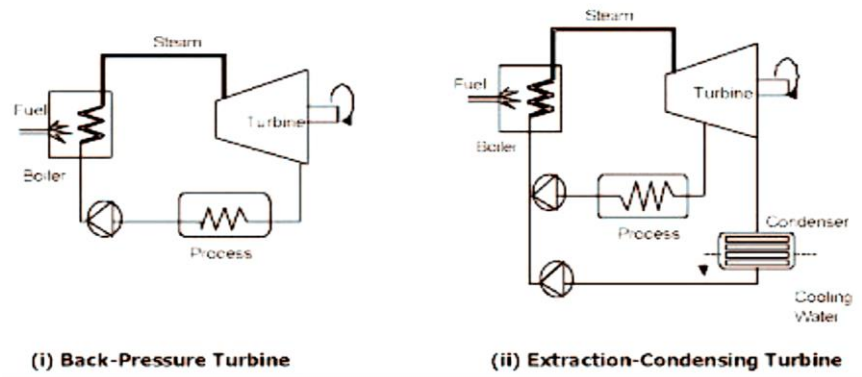

Figure 7.4.2: Schematic Diagrams of Steam Turbine Cogeneration Systems

The specific advantage of using STs in comparison with the other prime movers is the option for using a wide variety of conventional as well as alternative fuels such as coal, NG, fuel oil and biomass. The power generation efficiency (using Steam turbine 80%, Microturbine 60–70% and Fuel cell: 55–80%) of the demand for electricity is greater than one MW up to a few hundreds of MW. Due to the system inertia, their operation is not suitable for sites with intermittent energy demand.

#### 7.4.2 Gas turbine (GT) Cogeneration Systems

Gas turbine (GT) cogeneration systems can produce all or a part of the energy need of the site, and the energy released at high temperature (HT) in the exhaust stack can be recovered for various heating and cooling applications (see Figure 7.4.3). Though NG is most commonly used, other fuels such as light fuel oil or diesel (LDO, HSD) can also be used. The typical range of GTs varies from a fraction of a MW to around 100 MW.

Gas turbine CHP has probably experienced the most rapid development in the last 10-20 years (except selective units 5-7 years beyond that period) due to the greater availability of NG, rapid progress in the technology, significant reduction in installation costs, and better environmental performance. Furthermore, the gestation period for developing a project is shorter and the equipment can be delivered in a modular (segments package) manner. GT has a short start-up time and provides the flexibility of intermittent operation. Though it has a low heat to power conversion efficiency (65-70%), more heat can be recovered at higher temperatures. If the heat output is less than that required by the user, it is possible to have supplementary NG firing by mixing additional fuel to the oxygen-rich exhaust gas to boost the thermal output more efficiently.

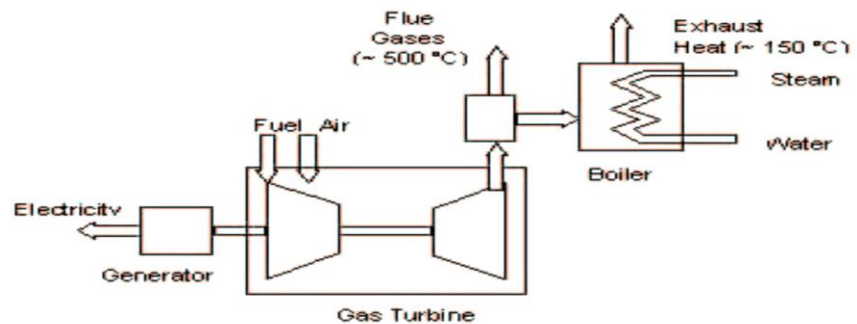
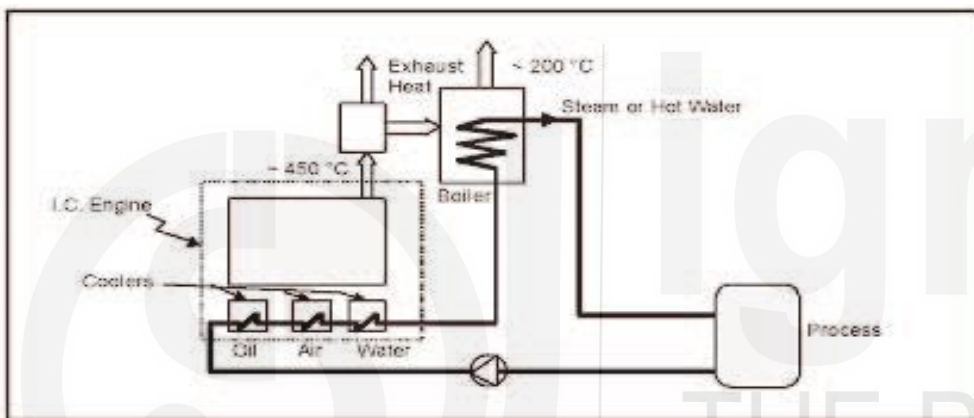

Figure 7.4.3: Schematic Diagram of Gas Turbine Cogeneration

On the other hand, if more power is required at the site, it is possible to adopt a combined cycle that is a combination of GT and ST cogeneration. Steam generated from the exhaust gas of the GT is passed through a backpressure or extraction-condensing ST to generate additional power. The exhaust or the extracted steam from the ST provides the required thermal energy.

### 7.4.3 Reciprocating Engine (REC) Cogeneration Systems

Also known as internal combustion (IC) engines, these CHP systems have high power generation efficiency (75-80%) in comparison with other prime movers. There are two sources of heat for recovery: exhaust gas at HT and engine jacket cooling water system at low temperature (LT - see **Figure 7.5.1**). As HR can be quite efficient for smaller systems, these systems are more popular with smaller energy consuming facilities, particularly those having a greater need for electricity than thermal energy and where the quality of heat required is not high, e.g. LP steam or hot water.



**Figure 7.5.1:** Schematic Diagram of Reciprocating Engine Cogeneration

Though diesel has been the most common fuel in the past, the prime movers can also operate with heavy fuel oil or NG. These machines are ideal for intermittent operation and their performance is not as sensitive to the changes in ambient temperatures as the gas turbines. Though the initial investment on these machines is low, their operation and maintenance (O&M) costs are high due to high wear and tear.

#### SAQ 1

1. Why is cogeneration power plant preferred in selective industries?
2. What do you mean by cogeneration?
3. Why to choose/use Cogeneration?
4. Explain how cogeneration is advantageous over conventional power plant.
5. How Does a Cogeneration Plant Work?
6. What are the different types of Cogeneration power plants?
7. What is meant by combined cycle cogeneration?

## 7.5 CLASSIFICATION OF COGENERATION SYSTEMS

Cogeneration systems are normally classified according to the sequence of energy use and the operating procedures/schemes adopted.

Cogen covers a wide range of proven technologies. CHP technologies can be divided into small scale applications, starting from some 1 kW of engines that are usually focused on thermal energy supply, up to large-scale power plants mainly focused on electric power production. These types of Cogen units/plants can be differentiated by technology and feasible capacity, as illustrated below. **Figure 7.5.2** shows the Schematic Diagrams of Cogeneration Capacity Range per Technology (MWe).

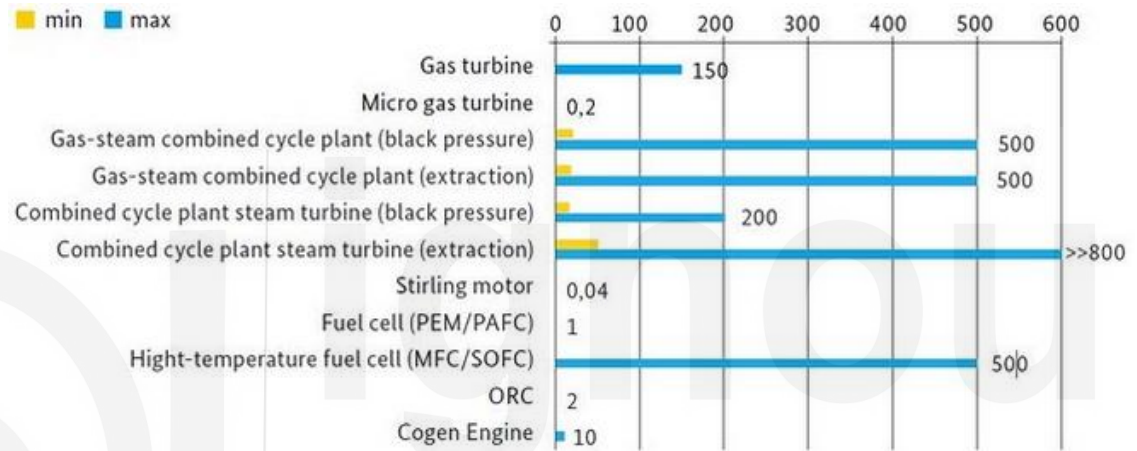

**Figure 7.5.2:** Schematic Diagram of Cogeneration Capacity Range Per Technology (MWe)

A Cogen system can be classified as either a topping or a bottoming cycle on the basis of the sequence of energy use. In a topping cycle, the fuel supplied is used to first produce power and then thermal energy, which is the by-product of the cycle and is used to satisfy process heat or other thermal requirements. Topping cycle CHP is widely used and is the most popular method of CHP. **Figure 7.5.3** shows the Schematic Diagrams of Topping cycle and Bottoming cycle.

**Check Your Progress 1**

Fill up the blanks.

1. The use of fossil fuels to create ----- is not doing great things for our planet, and we needed to create alternative ways in which to generate energy that weren't so detrimental.
2. EE measures are front-loaded in the Net Zero Emission (NZE), and they play their largest role in curbing energy demand and ----- in the period to 2030.
3. Indian power sector had brought out key changes, including, open access to the State grid transmission system on payment of mutually agreed ----- charges for facilitating new entrants on Captive power/Cogen route in restructuring of the sector around 1995 circular.
4. Cogeneration or CHP is the use of a ----- energy source to produce two forms of energy.
5. CHP reclaims the ----- (60-65% of input energy) heat loss and applies it to industry needs.
6. Factors influencing ----- choice: Matching of Base electrical & thermal load, Electrical & Thermal load.
7. CHP systems have ----- generation efficiency (75-80%) in comparison with other prime movers in IC engines.
8. Important technical parameters for Cogen: HTPR, Thermal energy quality needed, Load patterns, System reliability, ----- Vs ----- -, Retrofit Vs New Installation.
9. Overall ----- efficiency of an extraction condensing turbine CHP system is lower than that of back pressure turbine due to the exhaust heat cannot be utilized, but Cogen systems have higher electricity generation efficiency.

### Check Your Progress 2

Mark the correct answer

1. Which of following is not benefit of Cogen? (a) Increased efficiency of energy conversion/use (b) Reduced GHG emissions (c) Reduced power factor (d) Reduced transmission losses
2. Cogeneration is the simultaneous generation of ----- and ----- . (a) Heat and power (b) Mechanical energy and power (c) Steam and condensate (d) All of the above
3. What is an important advantage of closed-cycle gas turbine cogeneration systems? (a) Working fluid remains clean and it does not cause corrosion or erosion (b) Low capital costs (c) High pressure of produced steam (d) High temperature of produced steam
4. The cogeneration system which has a high overall efficiency is the ----- . (a) Gas turbine (b) Back pressure steam turbine (c) Reciprocating engine (d) Combined cycle
5. Which of the following statements is not correct? (a) A topping cycle plant generates electricity or mechanical power first (b) A bottoming cycle plant generates heat first (c) A bottoming cycle plant generates electricity or mechanical power first (d) Both a and b
6. How is the efficiency of cogeneration measured? (a) Electrical conversion (b) Thermal recovery (c) Both a and b (d) None of the above
7. What is a typical efficiency of a cogeneration system? (a) 58% (b) 68% (c) **85%** (d) 95%
8. Which fuel type can be used in GT? (a) Fuel oil (b) NG (c) Diesel d) All of the above.

#### Topping Cycle

Topping cycle - produces electricity first, and then the exhausted steam is used for heating. The hot water (HW) from condensed steam is well-suited for space and water heating. The four types of topping cycle cogeneration systems are briefly explained in **Table 7.1**.

#### Topping cycle system

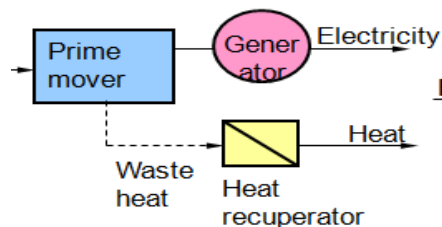

#### Bottoming cycle system

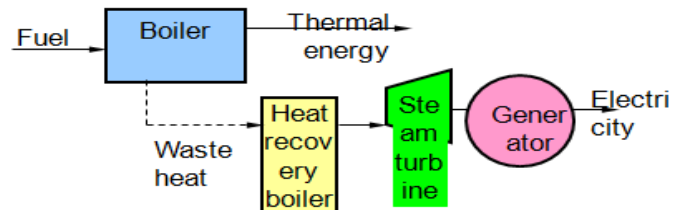

Figure 7.5.3: Schematic Diagram of Topping cycle and Bottoming cycle

**Check Your Progress 3**

Select True or False.

1. Topping cycle plants produce electricity from a steam turbine with WH being the main product.
2. Bottoming cycle plants are only used when the industrial process requires very medium temperatures, such as glass/metal manufacturing furnaces, hence it's rare.
3. Cogen or CHP is as likely to depend as much on economic conditions as EE optimization.
4. Two types of steam turbines most widely used are the backpressure and the extraction-condensing.
5. Though NG is most commonly used in gas turbines, other fuels such as light fuel oil or diesel (LDO, HSD) can also be used.
6. If the heat output is less than that required by the user, it is possible to have supplementary NG firing by mixing additional fuel to the oxygen-poor exhaust gas to boost the thermal output more efficiently.
7. Steam generated from the exhaust gas of the ST is passed through a backpressure or extraction-condensing ST to generate additional power.
8. Though the initial investment on the prime mover machines (or internal combustion engines) is low, their O&M costs are low due to high wear and tear.
9. Bottoming cycles are not suitable for manufacturing processes that require heat at HT in ovens/kilns/furnaces/dryers, and reject heat at significantly high temperatures.
10. Regardless, more than 50-55%  $\eta_{Net}$  is a factor driving the increasing popularity of combined cycle power, co-generation, and CHP technologies.
11. Centralized electricity generation near the point of use limits losses on transmission lines.
12. Different benefits of prime movers when it comes to Cogen are:  
Increased fuel efficiency and Reduced energy costs.

1.

Cogeneration systems are normally classified according to the sequence of energy use and the operating procedures/schemes adopted.

**Table 7.1:** Types of Topping Cycles

Sl. No.	Technology Description	Figure
1	A GT or diesel engine producing electrical or mechanical power followed by a HR boiler to create steam to drive a secondary ST. This is called a combined-cycle	

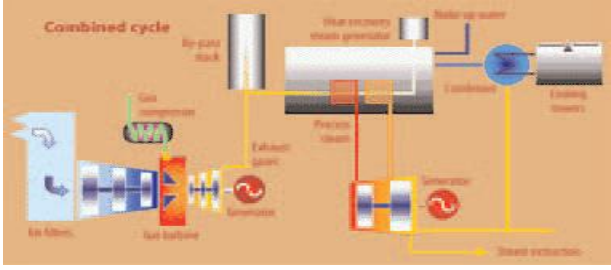
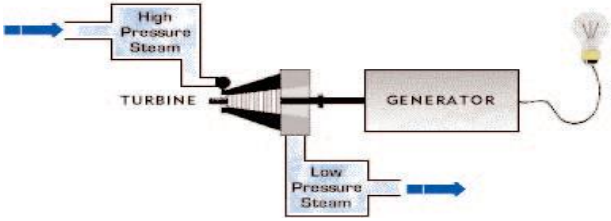
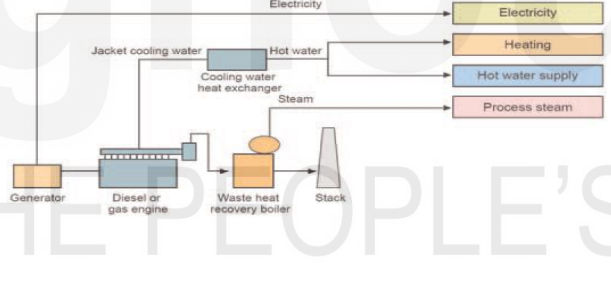
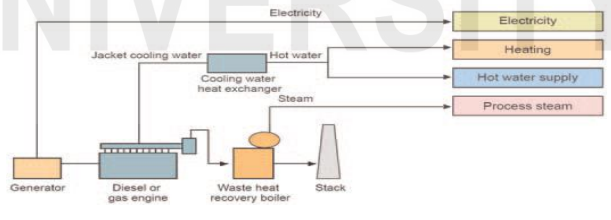
	topping system.	
2	The second type of system burns fuel (any type) to produce HP steam that then passes through a ST to produce power with the exhaust provides LP process steam. This is a ST topping system.	
3	A third type employs heat recovery from an engine exhaust and/or jacket cooling system flowing to a HR boiler, where it is converted to process steam/HW for further use.	
4	The fourth type is a GT topping system. A natural GT drives a generator. The exhaust gas goes to a HR boiler that makes process steam and process heat.	

**Bottoming Cycle**

In a bottoming cycle, the primary fuel produces high temperature  $E_{th}$  and the heat rejected from the process is used to generate power through a recovery boiler and a turbine generator. Bottoming cycles are suitable for manufacturing processes that require heat at HT in ovens, kilns, furnaces and dryers, and reject heat at significantly high temperatures. Typical areas of application include cement, steel, ceramic, NG and petrochemical industries. Bottoming cycle plants are much less common than topping cycle plants. The **Figure 7.5.4** illustrates the bottoming cycle where fuel is burnt in a furnace to produce synthetic rutile (a black or reddish brown mineral consisting of titanium dioxide). The waste gases coming

out of the furnace is utilized in a boiler to generate steam, which drives the turbine to produce electricity.

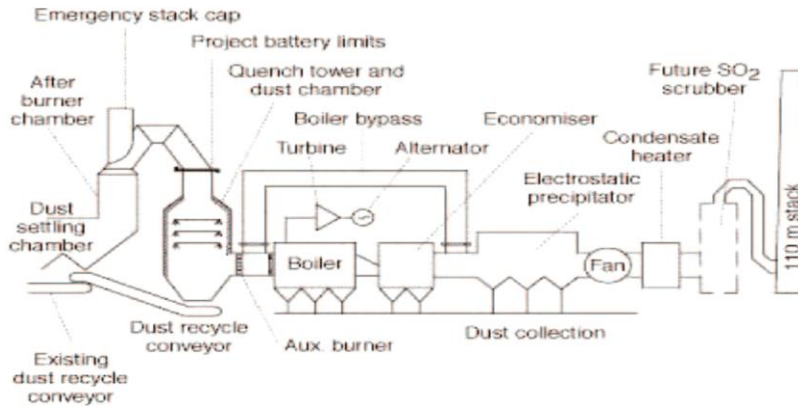

Figure 7.5.4: Bottoming Cycle

## 7.6 FACTORS INFLUENCING COGENERATION CHOICE

The selection and operating procedure/scheme of a CHP system is very much site/unit specific and depends on several factors, as described below:

### 7.6.1 Base electrical load matching

In this configuration, the CHP plant is sized to meet the minimum electricity demand of the unit based on the trend with real time data, projection (historical) demand curve. The rest of the needed power is purchased from the state level or utility grid. The  $E_{th}$  requirement of the unit could be met by the Cogen system alone or by additional boilers. If the  $E_{th}$  generated with the base electrical load exceeds the plant's demand and if the situation permits, excess thermal energy can be exported to neighboring units/customers.

### 7.6.2 Base Thermal Load Matching

Here, the Cogen system is sized to supply the minimum  $E_{th}$  requirement of the site. Stand-by boilers or burners are operated during periods when the demand for heat is higher. The prime mover installed operates at full load at all times. If the electricity demand of the site exceeds that which can be provided by the prime mover, then the remaining amount can be purchased from the grid. Likewise, if local laws permit, the excess electricity can be sold to the power utility.

### 7.6.3 Electrical Load Matching

In this operating scheme, the facility is totally independent of the power utility grid. All the power requirements of the site, including the reserves needed during scheduled and unscheduled maintenance, are to be taken into account while sizing the system. This is also referred to as a "stand-alone" system. If the  $E_{th}$  demand of the site is higher than that generated by the CHP system, auxiliary boilers are used. On the other hand, when the  $E_{th}$  demand is low, some thermal energy is wasted. If there is a possibility, excess  $E_{th}$  can be exported to neighboring facilities.

### 7.6.4 Thermal Load Matching

The cogeneration system is designed to meet the  $E_{th}$  requirement of the site at any time. The prime movers are operated following the thermal demand. During the period when the electricity demand exceeds the generation capacity, the deficit

can be compensated by power purchased from the grid. Similarly, if the local regulation permits, electricity produced in excess at any time may be sold to the utility.

---

## **7.7 IMPORTANT TECHNICAL PARAMETERS FOR COGENERATION**

---

While selecting cogeneration systems, one should consider some important technical parameters that assist in defining the type and operating procedure/scheme of different alternative Cogen systems to be selected.

### **7.7.1 Heat-to-Power Ratio (HTPR)**

Definition of heat-to-power ratio is thermal energy to electrical energy required by the industry. Heat-to-power ratio is one of the most important technical parameters influencing the selection of the type of Cogen system. The HTPR of a facility should match with the characteristics of the Cogen system to be installed. If the HTPR of plant/unit/factory can be matched with the characteristics of the cogeneration system being considered, the system optimization would be achieved in real sense.

Basic heat-to power ratios of the CHP system variants are shown in **Table 7.2** below along with some technical parameters. The steam turbine based cogeneration system can be considered over a large range of heat-to-power ratios.

It is defined as the ratio of thermal energy to electricity required by the energy consuming facility. Though it can be expressed in different units such as kCal/kWh, Btu/kWh, lb/hr/kW, etc., here it is presented on the basis of the same energy unit (kW).

CHP uses a single process to generate both electricity and usable heat or cooling. The proportions of heat and power needed (HTPR) vary from site to site, so the type of plant must be selected carefully and appropriate operating schemes/procedures must be established to match demands as closely as possible.

**Table 7.2:** Heat-To-Power Ratios and Other Parameters Of Cogeneration Systems

Sl. No.	Cogeneration system	Heat-to-power ratio (kW <sub>th</sub> /kW <sub>e</sub> )	Power output (as percent of fuel input)	Overall efficiency, %
1	Back-pressure steam turbine	4.0-14.3	14-28	84-92
2	Extraction-condensing steam turbine	2.0-10.0	22-40	60-80
3	Gas turbine	1.3-2.0	24-35	70-85
4	Combined cycle	1.0-1.7	34-40	69-83
5	Reciprocating engine	1.1-2.5	33-53	75-85

The unit may therefore be set up to supply part or all of the site heat and electricity loads, or an excess of either may be exported if a suitable customer is available.

The following **Table 7.3** shows typical HTPRs for certain energy intensive industries:

**Table 7.3:** Typical HTPRs For Certain Energy Intensive Industries

Sl. No.	Industry	Minimum	Maximum	Average
1	Breweries	1.1	4.5	3.1
2	Pharmaceuticals	1.5	2.5	2.0
3	Fertilizer	0.8	3.0	2.0
4	Food	0.8	2.5	1.2
5	Paper	1.5	2.5	1.9

Cogeneration is likely to be most attractive under the following circumstances:

- The demand for both steam and power is balanced i.e. consistent with the range of steam input: power output ratios that can be obtained from a suitable cogeneration plant.
- A single plant or group of units has sufficient demand for steam and power to permit economies of scale to be achieved.
- Peaks and troughs in demand can be managed or, in the case of electricity, adequate backup supplies can be obtained from the utility company.

The ratio of HTPR required by a site may vary during different times of the day and seasons of the year. Importing power from the grid can make up a shortfall in electrical output from the Cogen unit and firing standby boilers can satisfy additional heat demand.

Many large Cogen units utilize supplementary or boost firing of the exhaust gases in order to modify the HTPR of the system to match site loads.

### 7.7.2 Quality of Thermal Energy ( $E_{th}$ ) Needed

The quality of  $E_{th}$  required (temperature & pressure) also determines the type of Cogen system. For a sugar mill needing  $E_{th}$  at about 120°C, a topping cycle Cogen system can meet the heat demand. On the other hand, for a cement plant requiring thermal energy at about 1450°C, a bottoming cycle CHP system can meet both high quality  $E_{th}$  and electricity demands of the plant.

### 7.7.3 Load Patterns

The power and heat demand patterns of the user affect the selection (type & size) of the CHP system. For instance, the load patterns of two energy consuming facilities, Factory A and Factory B, shown in **Figure 7.7.1** would lead to two different sizes, possibly types also, of CHP systems.

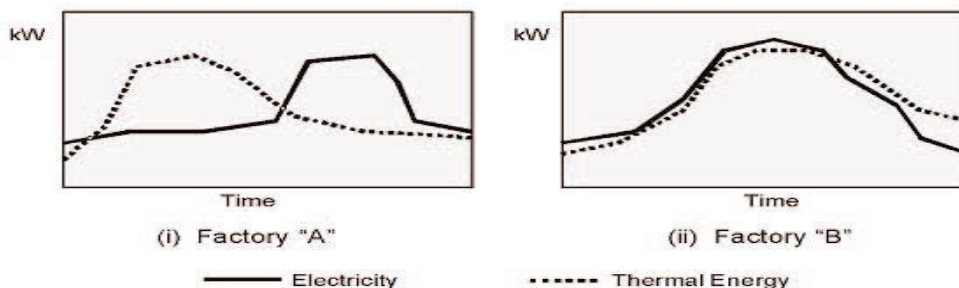

**Figure 7.7.1:** Different Heat and Power Demand Patterns in two Factories

#### 7.7.4 Fuels Available

Depending on the availability of fuels, some potential Cogen systems may have to be discarded (neglected). The availability of cheap fuels or waste products that can be used as fuels at a site is one of the major factors in the technical consideration because it determines the competitiveness of the CHP system.

A rice mill needs mechanical power for milling and heat for paddy drying. If a CHP system were considered, the ST system would be the first priority because it can use the rice husk as the fuel, which is available as waste product from the mill.

#### 7.7.5 System Reliability

Some energy consuming facilities require very reliable power and/or heat; for instance, a textile, pulp and paper industry cannot operate with a prolonged unavailability of process steam. In such instances, the Cogen system to be installed must be modular (independent system connected with common main steam header), i.e. it should consist of more than one unit so that shut down of a specific unit cannot seriously affect the energy supply.

#### 7.7.6 Grid Dependent System Versus Independent System

A grid dependent system has access to the grid to purchase or sell electricity. The grid independent system is also known as a “stand-alone” system that meets all the energy demands of the site. It is obvious that for the same energy consuming facility, the technical configuration of the Cogen or CHP system designed as a grid dependent system would be different from that of a stand-alone system.

#### 7.7.7 Retrofit Versus New Installation

If the Cogen system is installed as a retrofit (or modification), the system must be designed so that the existing energy conversion systems, such as boilers and auxiliary equipment, can still be used. In such a circumstance, the options for CHP system would depend on whether the system is a retrofit or a new installation.

#### 7.7.8 Electricity Buy-Back

The technical consideration of CHP system must take into account whether the local norms/regulations permit electric grids/utilities to buy electricity from the cogenerators or not. The size and type of Cogen system could be significantly different if one were to allow the export of electricity to the grid.

#### 7.7.9 Local Environmental Norm/Regulation

The local environmental regulations can limit the choice of fuels to be used for the proposed CHP systems. If the local environmental norms and regulations are stringent, some available fuels cannot be considered because of the high purification/treatment cost of the polluted exhaust gas and in some cases, the fuel itself.

---

### 7.8 PRIME MOVERS FOR COGENERATION

---

#### 7.8.1 Steam Turbine (ST)

Steam turbines (**Figure 7.8.1**) are the most commonly employed prime movers for Cogen applications. In the ST, the incoming high pressure (HP) steam is expanded

to a LP level, converting the thermal energy of HP steam to kinetic energy through nozzles and then to mechanical power through rotating blades.

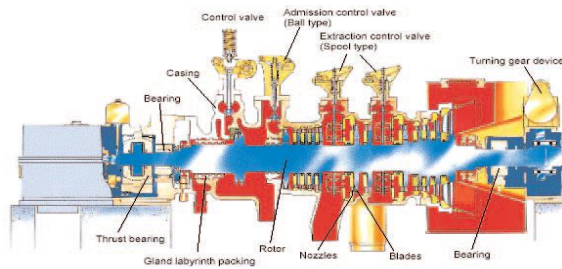

**Figure 7.8.1:** Steam Turbine

### Back Pressure Turbine

In this type steam enters the turbine chamber at HP and expands to LP or medium pressure (MP). Enthalpy difference is used for generating power/work. Depending on the pressure (or temperature) levels at which process steam is required, backpressure steam turbines can have different configurations as shown in **Figure 7.8.2**.

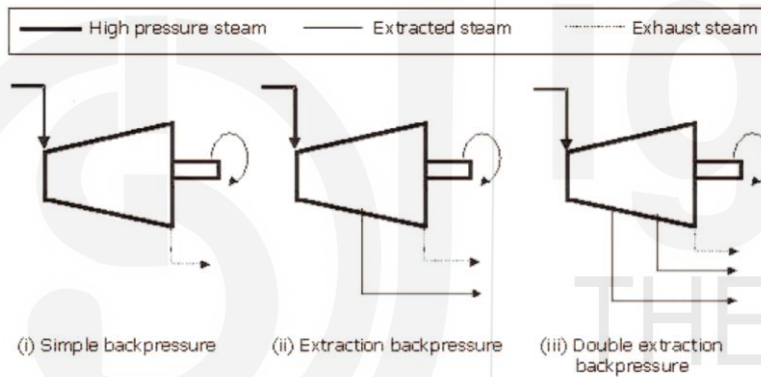

**Figure 7.8.2:** Different Configurations for Back Pressure Steam Turbines

In extraction and double extraction backpressure turbines, some amount of steam is extracted from the turbine after being expanded to a certain pressure level. The extracted steam meets the heat demands at pressure levels higher than the exhaust pressure of the steam turbine.

The efficiency of a backpressure ST Cogeneration system is the highest. In cases where 100% back pressure exhaust steam is used, the only inefficiencies are gear drive and electric generator losses, and the inefficiency of steam generation. Therefore, with an efficient boiler, the overall thermal efficiency of the system could reach as much as 90%.

### Extraction Condensing Turbine

In this type, steam entering at HP/MP is extracted at an intermediate pressure (IP) in the turbine for process use while the remaining steam continues to expand and condenses in a surface condenser and work is done till it reaches the Condensing pressure.(vacuum).

#### Do you know

The choice between backpressure turbine and extraction-condensing turbine depends mainly on the quantities of power and heat, quality of heat, and economic factors. The extraction points of steam from the turbine could be more than one, depending on the temperature levels of heat required by the processes. Another variation of the steam turbine topping cycle cogeneration system is the extraction-back pressure turbine that can be employed where the end-user needs thermal energy at two different temperature levels. The full-condensing steam turbines are usually incorporated at sites where heat rejected from the process is used to generate power.

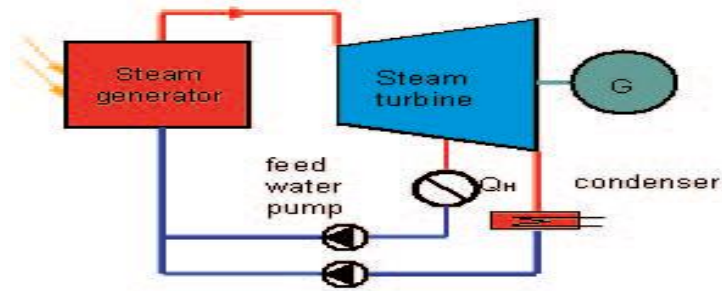

Figure 7.8.3: Extraction Condensing Turbine

In Extraction cum Condensing steam turbine as shown in **Figure 7.8.3**, HP steam enters the turbine and passes out from the turbine chamber in stages. In a two stage extraction cum condensing turbine MP steam and LP steam pass out to meet the process needs. Balance quantity condenses in the surface condenser. The Energy difference is used for generating power. This configuration meets the heat-power requirement of the process.

The extraction condensing turbines have higher power to heat ratio in comparison with backpressure turbines. Although condensing systems need more auxiliary equipment such as the condenser and cooling towers, better matching of electrical power and heat demand can be obtained where electricity demand is much higher than the steam demand and the load patterns are highly fluctuating.

The overall thermal efficiency of an extraction condensing turbine CHP system is lower than that of back pressure turbine system, basically because the exhaust heat cannot be utilized (it is normally lost in the cooling water circuit). However, extraction condensing Cogen systems have higher electricity generation efficiency.

### 7.8.2 Gas Turbine (GT)

The fuel is burnt in a pressurized combustion chamber using combustion air supplied by a compressor that is integral with the GT. In conventional GT (**Figure 7.8.4**), gases enter the turbine at a temperature range of 900 to 1000°C and leave at 400-500°C. The very hot pressurized gases are used to turn a series of turbine blades, and the shaft on which they are mounted, to produce mechanical energy. Residual energy in the form of a high flow of hot exhaust gases can be used to meet, wholly or partly, the thermal (steam) demand of the site. Waste gases are exhausted from the turbine at 450°C to 550°C, making the GT particularly suitable for high-grade heat supply.

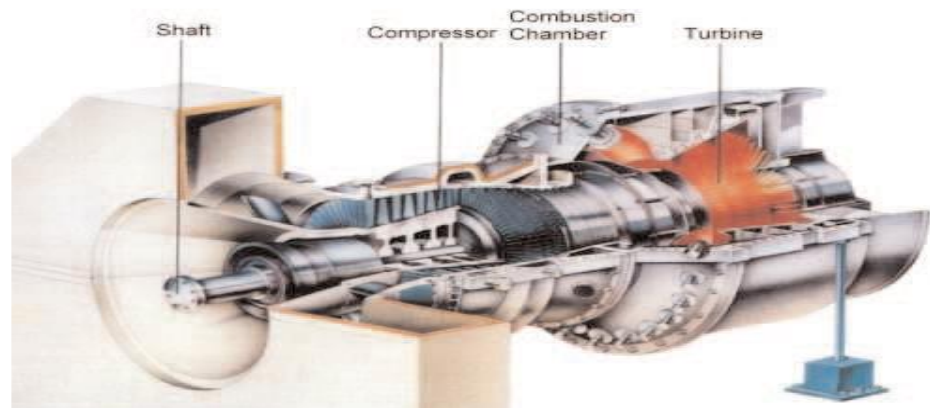

Figure 7.8.4: Gas Turbine

The available mechanical energy can be applied in the following ways:

- to produce electricity with a generator (most applications);
- to drive pumps, compressors, blowers, etc.

A GT operates under exacting conditions of high speed and HT. The hot gases supplied to it must therefore be clean (i.e. free of particulates which would erode the blades) and must contain not more than minimal amounts of contaminants, which would cause corrosion under operating conditions. High-premium fuels are therefore most often used, particularly NG. Distillate oils such as gas oil are also suitable, and sets capable of using both are often installed to take advantage of cheaper interruptible gas tariffs. LPGs and Naphtha are also suitable, LPG being a possible fuel in either gaseous or liquid form.

### Gas turbine (GT) efficiency

Turbine Efficiency is the ratio of actual work output of the turbine to the net input energy supplied in the form of fuel. For standalone Gas Turbines (GTs), without any HR system the efficiency will be as low as 35-40%. This is attributed to the blade efficiency of the rotor, leakage through clearance spaces, friction, irreversible turbulence etc. Since Exhaust gas from the GT is high, it is possible to recover energy from the hot gas by a Heat Recovery Steam Generator (HRSG) and use the steam for process.

### Net turbine efficiency

Above efficiency figures did not include the energy consumed by air compressors, fuel pump and other auxiliaries. Air compressor alone consumes about 50-60% of energy generated by the turbine. Hence net turbine efficiency, which is the actual energy output available. It will be less than what has been calculated. In most GT plants, air compressor is an integral part of Turbine plant.

### 7.8.3 Reciprocating engine system

This system provides process heat or steam from engine exhaust. The engine jacket cooling water heat exchanger and lube oil cooler may also be used to provide HW or hot air. There are, however, limited applications for this. As these engines can use only fuels like HSD, distillate, residual oils, NG, LPG etc. and as they are not economically better than ST/GT, their use is not widespread for Cogen. One more reason for this is the engine maintenance requirement. The reciprocating engine system is shown in **Figure 7.8.5**.

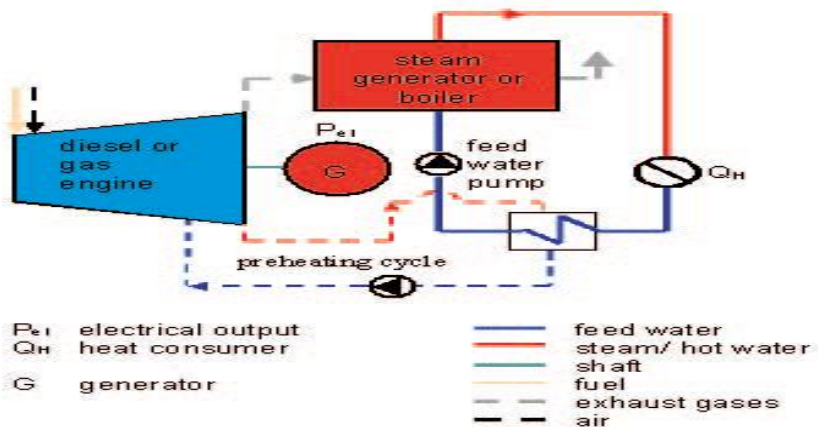

Figure 7.8.5: Reciprocating engine system

## 7.9 TYPICAL COGENERATION PERFORMANCE PARAMETERS

The following **Table 7.4** gives typical Cogeneration Performance Parameters for different Cogeneration Packages giving heat rate, overall efficiencies etc.

**Table 7.4:** Typical Cogeneration Performance Parameters

Sl. No.	Prime Mover in Cogen. Package	Nominal Range (Electrical, kW or MW)	Electrical Generation Heat Rate (kCal/kWh)	Efficiency, %		
				Electrical Conversion	Thermal Recovery	Overall Cogeneration
1	Smaller Reciprocating Engines	10–500	2650–6300	20–32	50	74–82
2	Larger Reciprocating Engines	500–3000	2400–3275	26–36	50	76–86
3	Diesel Engines	10–3000	2770–3775	23–38	50	73–88
4	Smaller Gas Turbines	800–10000	2770–3525	24–31	50	74–81
5	Larger Gas Turbines	10–20 MW	2770–3275	26–31	50	78–81
6	Steam Turbines	10–100 MW	2520–5040	17–34	–	–

## 7.10 BENEFITS/RELATIVE MERITS OF COMBINED CYCLE, COGEN AND CHP TECHNOLOGY SYSTEMS

Feedwater heating in power generating segment improves net efficiency ( $\eta_{Net}$ ) by several percent, but even with many thermodynamic improvements, the maximum net efficiency ( $\eta_{maxNet}$ ) of conventional drum units remains around 30% range. The most modern ultra super-critical (USC) boilers, advanced ultra super-critical (AUSC) boilers reportedly have exceeded 45% net efficiency ( $\eta_{NetUSC}$ ) and 50% net efficiency ( $\eta_{NetAusc}$ ) respectively. Regardless, less than 50-55%  $\eta_{Net}$  is a factor driving the increasing popularity of combined cycle power, co-generation, and CHP technologies. A common example comes from Cogen, where steam produces power in a non-condensing turbine(s) designed to leave the steam in a cooler but still superheated state at the turbine exhaust. The exhaust steam is distributed to other heat exchangers (HEs) for energy transfer that utilizes the remaining useful heat, including latent heat. Some co-generation processes may approach 80%  $\eta_{Net}$ , making it hard to argue against the economics of these processes.

The following **Table 7.5** gives the advantages and disadvantages of various Cogeneration systems:

**Table 7.5:** Advantages and Disadvantages Of Various Cogeneration Systems

Sl. No.	Variant	Advantages	Disadvantages
1	Back pressure	- High fuel efficiency rating	- Little flexibility in design and operation
2	Steam turbine & fuel firing in boiler	- Simple plant - Well-suited to low quality fuels	- More capital investment - Low fuel efficiency rating - High cooling water demand - More impact on environment High civil const. cost due to complicated foundations
3	Gas turbine with WHR boiler	- Good fuel efficiency - Simple plant - Low civil const. Cost - Less delivery period - Less impact on environment - High flexibility in operation	- Moderate part load efficiency - Limited suitability for low quality fuels
4	Combined gas & steam turbine with WHR boiler	- Optimum fuel efficiency rating - Low relative capital cost - Less gestation period - Quick start up & stoppage - Less impact on environment - High flexibility in operation	- Average to moderate part-load efficiency - Limited suitability for low quality fuels
5	Diesel Engine & WHR boiler & cooling water heat exchanger	- Low civil const. Cost due to block foundations & least no. of auxiliaries - High Power efficiency - Better suitability as stand by power source	- Low overall efficiency - Limited suitability for low quality fuels - Availability of low temperature steam - Highly maintenance prone

Along with the saving of fossil fuels, cogeneration also allows to reduce the emission of GHGs (particularly CO<sub>2</sub> emission). The production of electricity being on-site, the burden on the utility network is reduced and the transmission line losses eliminated.

Cogen makes sense from both macro and micro perspectives. At the macro level, it allows a part of the financial burden of the national power utility to be shared by the private sector; in addition, indigenous energy sources are conserved. At the micro level, the overall energy bill of the users can be reduced, particularly when there is a simultaneous need for both power and heat at the site, and a rational energy tariff is practiced in the country.

The success of the Cogen or CHP project will be evaluated against the following basis:

- CHP unit must meet electrical equipment specifications and size constraint.
- CHP system must achieve overall energy efficiency of greater than 80%.
- CHP design and operation is to be in compliance with GOI's Environmental Protection Act, Occupational Health and Safety Act etc.
- Capital project must be proven economically feasible and offer cost savings.
- CHP system should provide environmental benefits (such as reduction in air pollutant emissions).

The most commonly used energy sources are steam (steam turbine) and natural gas (gas-fired engine and turbine), though some applications use diesel and biogas.

If the HTPR varies throughout the day or across seasons, any change in the quantity of electricity generated, or any purchase of electricity, can result in a significant loss of earnings. Therefore, it is preferable to adjust the HTPR to the needs of the site by using an additional burner at the intake of the HR boiler or a supplementary boiler. Optimizing a Cogen system (i.e. adapting it to heat requirements) yields the following main benefits:

Economic and environmental benefits:

- Increase in the  $\eta_{ov}$  with which fuel is converted into heat and electricity;
- Access to income from the sale of excess electricity to the grid;
- Reduced cost of treating effluents and disposing of waste when biogas is used, increasing the profitability of the system;
- Reduced atmospheric emissions, especially CO<sub>2</sub> and nitrogen oxides (NO<sub>x</sub>).

Greater security of electricity supply: Cogen plant reduces the risk of production disruption in the event of a power failure.

Decentralized electricity generation near the point of use limits losses on transmission lines.

The application has been tested in most industrial sectors around the world, especially in several processes in the food and beverage industry as well as agriculture. In general, Cogen requires a large investment with a payback period of four to five (4-5) years. The cost of purchasing the equipment and connecting it to the process and the electricity grid must be added to the cost of building a chamber or structure to attenuate the noise produced by gas turbines and engines. Therefore, any decision to build a Cogen plant should account for the following elements:

- Annual thermal energy and electricity needs of the process, their seasonal variations and forecasts of future developments;
- Potential for energy savings - A detailed energy audit designed to optimize energy use at the establishment should be performed before launching any cogeneration project. It may, in fact, happen that, after Cogen is in place, it becomes more difficult to further improve EE;
- Type of fuel used and forecasts of trends in its price and the price of electricity;
- Cost of investing in equipment and the civil infrastructure; and
- Existing incentive programs.

---

## 7.11 ENERGY PERFORMANCE ASSESSMENT OF COGENERATION

---

Steam turbine cogeneration systems involve different types of configurations with respect to mode of power generation such as extraction, back pressure or a combination of backpressure, extraction and condensing.

GTs with HRSGs is another mode of cogeneration. Depending on power and steam load variations in the plant the entire system is dynamic. A performance assessment would yield valuable insights into cogeneration system performance and need for further optimization.

### 7.11.1 Performance Purpose, Terms and Definitions

ASME Performance Test Codes is used for conducting the Performance test of Cogen plant. The purpose of the Cogen plant performance test is to determine the power output and plant heat rate (HR, /in kCal/kWh). In certain cases, the efficiency of individual components like ST is addressed specifically where performance deterioration is suspected. In general, the plant performance will be compared with the base line values arrived at for the plant operating condition rather than the design values. The other purpose of the test is to show the maintenance accomplishment after a major (annual) overhaul. In some cases the purpose of evaluation could even be for a total plant revamp.

#### Overall plant performance

1. Overall plant heat rate, kCal/kWh

$$= \frac{\text{Mass flow rate of steam} \times (\text{Enthalpy of steam, } \frac{\text{kCal}}{\text{kg}} - \text{Enthalpy of feed water, } \frac{\text{kCal}}{\text{kg}})}{\text{Power output, kW}}$$

2. Overall plant fuel rate kg/kWh =  $\frac{\text{Fuel consumption* in kg/hr}}{\text{power output, kW}}$

\*Total fuel consumption for turbine and steam

#### Steam turbine performance

$$\text{Turbine cylinder efficiency, \%} = \frac{\text{Actual enthalpy drop across the turbine, kCal/kg}}{\text{Isentropic (theoretical) enthalpy drop across the turbine, kCal/kg}} \times 100$$

#### Gas turbine performance

$$\text{Air compressor efficiency, \%} = \frac{\text{Theoretical temperature rise across the compressor, } ^\circ\text{C}}{\text{Actual temperature rise, } ^\circ\text{C}} \times 100$$

$$\text{Overall Gas Turbine efficiency (Compressor + Gas turbine), \%} = \frac{\text{Power output, kW} \times 860}{\text{Fuel input for gas Turbine, kg/hr} \times \text{GCV of Fuel, kCal/kg}}$$

### HRSG performance

Heat recovery Steam Generator Efficiency, %

$$= \frac{\text{steam generated, kg/hr} \times (h_s, \text{kCal/kg} - h_w, \text{kCal/kg})}{[\text{Mass flow of flue gas, kg/hr} \times Cp \times (t_{in} - t_{out})] + [\text{auxiliary fuel consumption, kg/hr} \times \text{GCV of fuel, kCal/kg}]} \times 100$$

Where,  $h_s$  = Enthalpy of steam  
 $h_w$  = Enthalpy of feed water  
 $t_{in}$  = inlet temperature of flue gas  
 $t_{out}$  = outlet temperature of flue gas

Modern power station practices by British Electricity International (Pergamon Press) ASME PTC 22 - Gas turbine performance test.

### Test duration

The test duration is site specific and in a continuous working process, power industry, 8-hour test data should give reasonably reliable data. In case of an industry with fluctuating electrical/steam load profile a set 24-hour data sampling for a representative period.

It is essential to ensure that the data (Steam supply flow, Fuel input flow, Air flow/Flue gas flow, Flue gas Analysis, Unburnt carbon analysis, Temperature, Cooling water flow, Pressure, Power and Condensate return flow) is collected during steady state plant running conditions. Among others the following are essential details to be collected for cogeneration plant performance evaluation.

## 7.12 CASE STUDY: APPLICATIONS OF SMALL COGENERATION PLANT IN DISTILLERY

A distillery plant having an average production of 40 kilolitres of ethanol is having a cogeneration system with a backpressure turbine. The plant steam and electrical demand are 5.1 Tons/hr and 100 kW. The process flow diagram is shown in **Figure 7.12.1**. Gross calorific value of Indian coal is 4000 kCal/kg.

Calculations:

**Step 1:** Total heat of steam at turbine inlet conditions at 15kg/cm<sup>2</sup> and 250°C,  $h_1$  = 698 kCal/kg.

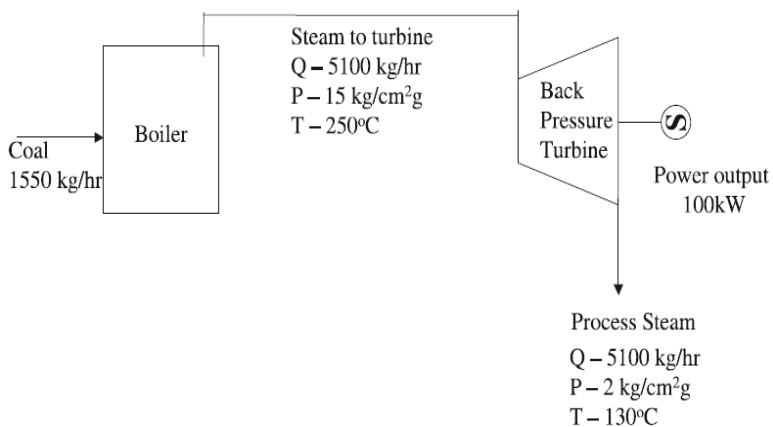

**Figure 7.12.1:** Process Flow Diagram for Small Cogeneration Plant

**Step 2:** Total heat of steam at turbine outlet conditions at  $2 \text{ kg/cm}^2$  and  $130^\circ\text{C}$ ,  $h_2 = 648 \text{ kCal/kg}$ .

**Step 3:** Heat energy input to turbine per kg of inlet steam  $(h_1 - h_2) = (698 - 648) = 50 \text{ kCal/kg}$ .

**Step 4:** Total steam flow rate,  $Q_1 = 5100 \text{ kg/hr}$ ; Power generation =  $100 \text{ kW}$ ; Equivalent thermal energy =  $100 \times 860 = 86,000 \text{ kCal/hr}$ .

**Step 5:** Energy input to the turbine =  $5100 \times 50 = 2,55,000 \text{ kCal/hr}$ .

**Step 6:** Power generation efficiency of the turbo alternator

$$= (\text{Energy output}/\text{Energy input}) \times 100 = (86000/255000) \times 100 = 34\%$$

**Step 7:** Efficiency of the turbo alternator =  $34\%$ ;

Efficiency of Alternator =  $92\%$ ; Efficiency of gear transmission =  $98\%$

$$\begin{aligned} \text{Efficiency of turbine} &= \text{Power generation efficiency of turbo} \\ &\text{alternator}/(\text{Efficiency of gear transmission} \times \text{Efficiency of alternator}) \\ &= 0.34/(0.98 \times 0.92) = 0.38 \end{aligned}$$

**Step 8:** Quantity of steam bypassing the turbine = Nil

**Step 9:** Coal consumption of the boiler =  $1550 \text{ kg/hr}$ .

**Step 10:**

Coal consumption Overall plant heat rate,  $\text{kCal/kWh}$

$$= \text{Mass flow rate of steam} \times [(\text{Enthalpy of steam, kCal/kg} - \text{Enthalpy of feed water, kCal/kg})/\text{Power output, kW}]$$

$$= 5100 \times [(698 - 30)/100] = 34068 \text{ kCal/kWh}^*$$

**\*Note:** The plant heat rate is about of  $34000 \text{ kCal/kWh}$ , because of the use of backpressure turbine. This value will be around  $3000 \text{ kCal/kWh}$  while operating on fully condensing mode. However, the energy in the steam is not wasted with backpressure turbine, as it is utilized in the process.

Overall plant fuel rate including boiler =  $1550/100 = 15.5 \text{ kg Coal/kW}$ .

### Analysis of Results:

The efficiency of the turbine generator set is as per manufacturer design specification. There is no steam bypass indicating that the power generation potential of process steam is fully utilized. At present the power generation from the process steam completely meets the process electrical demand or in other words, the system is balanced.

### Remarks:

Similar steps can be followed for the evaluation of performance of gas turbine based cogeneration system.

**SAQ 2**

1. What is meant by wheeling?
2. Define the term topping cycles with example.
3. Define the term bottoming cycles with example.
4. Explain the term heat-to-power ratio
5. Explain the principle of operation of a steam turbine.
6. Explain the principle of operation of a gas turbine.
7. What is meant by plant heat rate? What is its significance?

**SUGAR COMPANY CASE STUDY: APPLICATIONS OF  
COGENERATION PLANT**

The Sugar Company is located in Andhra Pradesh. It has a crushing capacity of 8,000 TCD (tons crushed per day) in two mill tandem. Cogeneration was planned in two phase with 13.5 MW capacity in each phase. The following **Table 7.6** gives typical Cogeneration Performance Parameters details in Sugar Company.

**Table 7.6:** Typical Cogeneration Plant Performance Details

<b>Boiler</b>	
<b>Type</b>	<b>Single drum water tube radiant with dumping grate</b>
Fuel used	Bagasse/rice husk
Capacity	82 tph
Steam pressure	63 ata
Steam temperature	485 °C
Total hearing surface	3,913 sq.m
ID fan (2 nos.) with VFDs	162,000 m <sup>3</sup> /hr each
FD fan (2 nos.) with VFDs	72,000 m <sup>3</sup> /hr each
SA fan ( no.)	54,000 m <sup>3</sup> /hr
Fly ash control	Wet scrubber

**Turbo Alternator**

Rating	25 MW*
Type	Extraction-cum-condensing
Operating pressure & Temperature	71 ata/485°C
Specific steam consumption	6 kg/kWh (season) 4.5 kg/kWh (off-season)
Governor type	Hydraulic (original governor)
Rating	31.5 MVA, 25 MW at 6.3 kV 50 Hz
RPM	3,000 (direct coupling to turbine)
Insulation	Class B

## Performance data of the Cogeneration Unit

	2003-2004	2004-2005
No. of days of operation	103	132
Average cost of fuel per ton		
Bagasse:	Rs. 923	Rs. 1,004
Husk:	Rs. 905	Rs. 1,232
Coal:	Rs. 2,176	Rs. 2,264
Electricity generated, kWh	124,533,700	38,758,690
Electricity exported, kWh	15,670,000	24,184,000
Revenue realised from power export	Rs. 53,733,220 @ Rs. 3.48/kWh	Rs. 64,448,752 @ Rs. 3.085/kWh
Crane crushed, tons	8,51,000	9,27,000
Average cane crushed, tph	7,340	7,566 (excluding stoppage)
Recovery % cane	10.83	11.57
Fibre % cane	14.21	13.85
Operation time efficiency % (hours lost % available)	9.65	7.73

### CEMENT COMPANY CASE STUDY: APPLICATIONS OF COGENERATION PLANT

This case study is from India Cements, A.P. It is the utilization of waste heat from the pre-heater and AQC gases for power generation. Steam is produced in a HRSG and the super heated steam drives a turbo-generator, producing electricity. This system is utilizing thermal energy, which discharged into the atmosphere. About 40% of the input energy is in typical exhaust systems. The power generated is about 30 % of total power required for the plant.

The typical Cogeneration Performance operating parameters of the pre-heater and AQC exhaust gas system in a Cement Company is given below in Table 7.7 and Table 7.8 respectively.

**Table 7.7:** Typical Cogeneration Plant Exhaust gas data

Items	UNIT	PH	AQC	
Volumetric flow rate	Nm <sup>3</sup> /h	360,750	191,600	
Boiler Pressure (flue gases)	kpaG	-9.01	-0.25	
Temperature at Boiler inlet	Deg. C	340	360	
Temperature at Boiler outlet	Deg. C	230	90	
Gas composition	N <sub>2</sub>	Vol %	60	77.6
	O <sub>2</sub>	Vol %	4	20.4
	H <sub>2</sub> O	Vol %	7	2
	CO <sub>2</sub>	Vol %	29	-
Dust Content	G/Nm <sup>3</sup>	50-60	5 <sup>*1</sup>	
Duct Diameter	mm	3800	4300	

**Table 7.8:** Typical Cogeneration Plant Detail of steam and power generation data

Items		Unit	PH Boiler	AQC Boiler
Boilers	Evaporation Rate	T/H	28.20	14.63
	Steam Pressure	MpaG	1.57	1.70
	Steam Temp	Deg. C	315	345
	Feed Water Temp	Deg. C	200	56
	Heat Recovery Value	Kl/h	63,773,337	34,070,001
Steam Turbine	Output	KW	7,700	
Generator	Capacity	KVA	9,625	
	Power Factor	%	60	
	Terminal Voltage	V	6,600	
	Frequency	Hz	50	

Cost benefit analysis is given below. Note that the auxiliary consumption of the cooling power, boiler feed pumps, fans etc has been accounted and net power generate is calculated.

Quantity of power generated	KW	7,700
In-house power consumption	KW	800
Net quantity of power generated	KW	6,900
Quantity of cooling water	T/h	26.5
Cooling water pump	KW	180
Reduced power purchased	KW	7,060
Price power purchased	Rs./kwh	4.15
Annual reduction of quantity of power purchased	10 <sup>6</sup> kwh	56.07
Annual saving of power fee	Million Rs. /y	232.7
Reduced cost per ton of product	Rs. /1	581.8

### 7.13 LET US SUM UP

For one hundred or two hundred years, people have been used to connect energy and coal, oil and natural gas. As fuel prices continue to escalate the relevance of efficient energy is apparent to companies everywhere, from the smallest concern to the largest multinational. With an increased interest in eco-friendly ways for a sustainable future, the topic of electricity production was bound to become a well-versed discussion around the world. The industrial sector has a massive need for heat and electricity. Some industries primarily use heat, like metal manufacturers, while some use mostly electricity. Other industries require both heat and electricity in varying ratios. Each scenario can benefit from a recycled energy system. A factory that requires more electricity than heat can sell the heat to a utility and excess electricity can similarly be sold. The methods and techniques adopted to improve energy utilization will vary depending on circumstance, but the basic principle of reducing energy costs relative to productivity will be the same. As such, field of Cogen and energy conservation calls for a new insight into the new source of energy as well the conventional sources coupled with WHR, Cogen or

CHP that can be employed in various industries as well as in commercial building applications. This Unit 7 presents an overview of a variety of Cogen systems.

CHP is a technology that produces electricity and thermal energy ( $E_{th}$ ) at high efficiency using a range of technologies and fuels. With on-site power production, losses are minimized and heat that would otherwise be wasted is applied to facility loads in the form of process heating, steam, HW, or even chilled water. CHP can be located at an individual facility or building or it can be a space heating, microgrid, and/or utility resource that provide power and  $E_{th}$  to multiple end-users. CHP equipment can provide regular flexible power in the event of grid interruptions, and it can be associated and balanced with other distributed energy technologies like solar photovoltaics (SPV) and energy storage.

The efficiency of cogeneration can vary with technology, dimensions, boundary conditions and fuels, but high efficiency gains of 30% and more compared to separate generation of heat and power are common. It is important to mention that this efficiency relates to the aggregate - electric and thermal - efficiency.

The influence of boundary conditions on system efficiency can be illustrated by a simple example: CHP is most efficient when the heat can be used on-site or very close to it. Overall efficiency ( $\eta_{ov}$ ) is reduced when the heat must be transported over longer distances. This requires heavily insulated pipes, which are expensive and inefficient.

The type of equipment that drives the overall system (i.e. the prime mover) typically identifies the CHP system. Prime movers for CHP systems include reciprocating engines, combustion or gas turbines, steam turbines, micro-turbines, and fuel cells. The benefits when it comes to Cogen are numerous. However, we have just included a few of the major points below.

Increased fuel efficiency: Cogen is known for its high efficiency levels, meaning less fuel are needed to create similar levels of electricity and heat in comparison to other systems. This makes it a great eco-friendly option for fuel optimization.

Reducing energy wastage: This is a big environmental plus - if waste is being used to power cogeneration systems, this means less is going into our landfills.

Reduced energy costs: The more efficient a system is in creating electricity and heat, the lower your energy costs are going to be - that seems like a big advantage of cogeneration.

Reduced greenhouse gas emissions: This is a big one - less greenhouse gases means a happier and healthier environment for all!

Reduced reliance on the grid: If you are using a CHP system that means you are not relying on a greater electricity grid, meaning better energy security and you can run completely 'off-grid', or supplement higher energy demands.

Various fuel options: Various fuels can be used in cogeneration, including town gas, NG, methane, diesel, biodiesel and propan, LPG gases. This offers a level of flexibility, meaning you aren't required to only use one type of fuel at all times and aren't limited should a type of fuel be in short supply.

There are basically two types of cogeneration power plants, as given below. In a topping cycle, fuel is burned to produce HT heat, which is utilized in a turbine to generate electrical or mechanical power. After passing through the turbine, the reject heat is then used in industrial applications as process heat. On the other

hand, in a bottoming cycle system, fuel is burned initially to produce process heat, with the reject heat used to generate either electrical or mechanical power.

Topping Cycle Power Plant:

In this type of CHP plant electricity is generated first and then waste or exhaust steam is used to heating water or building. There are basically four types of topping cycles.

- Combined-cycle topping CHP plant - In this type of plant the fuel is firstly burnt in a steam boiler. The steam so produced in a boiler is used to drive turbine and hence synchronous generator which in turn produces electrical energy. The exhaust from this turbine can be either used to provide usable heat, or can be sending to a heat recovery system to generate steam, which maybe further used to drive a secondary steam turbine.

- Steam-turbine topping CHP Plant- In this the fuel is burned to produce steam, which generates power. The exhaust steam is then used as low-pressure process steam to heat water for various purposes.

- Water turbine topping CHP Plant- In this type of CHP plant a jacket of cooling water is run through a heat recovery system to generate steam or hot water for space heating.

- Gas turbine topping CHP plant- In This topping plant a natural gas fired turbine is used to drives a synchronous generator to produce electricity. The exhaust gas is sent to a heat recovery boiler where it is used to convert water into steam, or to make usable heat for heating purposes.

Bottoming Cycle Power Plant:

As its name indicate bottoming cycle is exactly opposite of topping cycle. In this type of CHP plant the excess heat from a manufacturing process is used to generate steam, and this steam is used for generating electrical energy. In this type of cycle no extra fuel is required to produce electricity, as fuel is already burnt in production process.

Energy and environmental engineering based cogeneration technology will be conducive to the norm, regulation of environmental protection and pollution prevention management mandatory measures implementation, but also conducive to improve the awareness on Cogen and environment of all levels of government, corporate and industry and agriculture and other energy intensive and polluting Small and Medium Enterprises (SMEs), to better promote them to take more effective action. It has obvious technical, economic, environmental and social benefits and it is of great significance to alleviate the current situation of electric power deficit.

**Check Your Progress 4**

Select Yes or No.

1. Prime mover, generally a turbine/thermal engine or turbine/combination of engines which converts chemical energy of fuel into mechanical energy transmitted to electrical generator.
2. Energy recovery can be maximized by installing a standard economizer at the outlet of the HR boiler (exhaust temperature, which ranges from 120°C to 150°C, depending on the fuel, can also be increased).
3. CHP technologies can be divided into small scale applications, starting from some 1 kW of engines that are usually focused on thermal energy supply, up to large-scale power plants mainly focused on electric power production.
4. Typical areas of bottoming cycle plants application include cement, steel, ceramic, natural gas and petrochemical industries.
5. A third type employs heat recovery from an engine exhaust and/or jacket cooling system flowing to a HR boiler, where it is converted to process steam/HW for further use.
6. The HTPR of a facility should mismatch with the characteristics of the Cogen system to be installed.
7. If the HTPR of factory can be matched with the characteristics of the Cogen system being considered, the system optimization would be achieved in real sense.
8. The HTPR proportions required vary from site to site, so the type of plant must be selected carefully and appropriate O&M procedures must be established to match demands as closely as possible.
9. Installed Cogen system must be modular (independent system connected with common main steam header) so that shut down of one unit at a time cannot seriously affect the energy supply.
10. Depending on the pressure (or temperature) levels at which process steam is required, backpressure steam turbines cannot have different configurations.
11. Waste gases are exhausted from the turbine at 450°C to 550°C, making the Gas Turbine particularly suitable for high-grade heat supply.
12. Since Exhaust gas from the GT is high, it is possible to recover energy from the cold gas by a Heat Recovery Steam Generator (HRSG) and use the steam for process.

### Check Your Progress 5

Give the term for the following.

1. In a Cogen cycle, the fuel supplied is used to first produce power and then thermal energy, as by-product of cycle and is used to satisfy process heat/other thermal needs.
2. In a Cogen cycle, the primary fuel produces high temperature thermal energy and heat rejected from the process is used to generate power through a recovery boiler and a turbine generator.
3. A GT or diesel engine producing electrical or mechanical power followed by a HR boiler to create steam to drive a secondary ST.
4. The type of system burns fuel (any type) to produce HP steam that then passes through a ST to produce power with the exhaust provides LP process steam.

A natural GT drives a generator. The exhaust gas goes to a HR boiler that makes process steam and process heat.

## 7.14 GLOSSARY

Cogen :	Cogeneration;
EE :	Energy Efficiency;
kW :	Kilo Watt;
kWh :	Kilo Watt hour;
kCal :	Kilo Calorie;
Btu :	British thermal unit;
MWe :	Mega Watt energy;
WH :	Waste Heat;
HR :	Heat Recovery;
HR <sub>t</sub> :	Heat rate (in kCal/kWh);
WHR :	Waste Heat Recovery;
HR <sub>max</sub> :	Maximum heat recovery;
HRSG :	Heat Recovery Steam Generator;
CHP :	Combined Heat and Power;
E <sub>th</sub> :	Thermal energy;
REC :	Reciprocating engine cogeneration;
ICE :	Internal combustion engine;
HTPR :	Heat-to-power ratio;
E <sub>CHP</sub> :	Electricity from cogeneration;
$\eta_{avg}$ :	Average efficiency;
$\eta_{Net}$ :	Net efficiency;

$\eta_{\text{NetUsc}}$	: Net efficiency of ultra super-critical;
$\eta_{\text{NetAusc}}$	: Net efficiency of advanced ultra super-critical;
$\eta_{\text{ov}}$	: Overall efficiency of the system;
$\eta_{\text{optm}}$	: Optimum efficiency;
HW	: Hot water;
$T_a$	: Ambient temperature;
$T_{\text{max}}$	: Maximum temperature;
HT/LT	: High temperature/Low temperature;
LP	: Low pressure;
MP	: Medium pressure;
IP	: Intermediate pressure;
HP	: High pressure;
ST	: Steam turbine;
GT	: Gas turbine;
HE	: Heat exchanger;
O&G	: Oil and Gas;
NG	: Natural gas;
LDO	: Light diesel oil;
HSD	: High speed diesel oil;
LPG	: Liquefied petroleum gas;
GCV	: Gross calorific value;
$T_{\text{in}}/t_{\text{out}}$	: Steam temperature at inlet/outlet;
$h_w/h_s$	: Enthalpy of feed water/steam;
SPV	: Solar photovoltaics;
GHG	: Greenhouse gas;
O&M	: Operation and Maintenance;
CO <sub>2</sub>	: Carbon dioxide;
NO <sub>x</sub>	: Nitrogen oxides;
N <sub>2</sub> O	: Nitrous oxides;
SO <sub>2</sub>	: Sulphur dioxide;
ASME PTC	: ASME Performance Test Codes;
GDP	: Gross domestic product;
SME	: Small and Medium Enterprises;
GOI	: Govt. of India.

ignou  
THE PEOPLE'S  
UNIVERSITY

---

## 7.15 ANSWER TO CHECK YOUR PROGRESS

---

### Check Your Progress 1

Electricity, Emissions, Wheeling, Single, Waste, Cogeneration, High, Grid  
Dependent Vs Independent System, Thermal.

### Check Your Progress 2

(c) Reduced power factor, (a) Heat and power, (a) Working fluid remains clean  
and it does not cause corrosion or erosion, (d) Combined cycle, (c) A bottoming  
cycle plant generates electricity or mechanical power first, (c) Both a and b, (c)  
85%, (d) All of the above.

### Check Your Progress 3

(1) Byproduct – TRUE (2) High temperature - TRUE (6) Rich – TRUE (7) GT –  
TRUE (8) High – TRUE (9) Suitable – TRUE (11) Decentralized – TRUE.

### Check Your Progress 4

Yes, No (Decreased), Yes, Yes, Yes, No (Match), Yes, Yes, Yes, No (Can), Yes,  
No (Hot).

### Check Your Progress 5

1. Topping Cycle.
2. Bottoming Cycle.
3. Combined-cycle topping system.
4. Steam Turbine topping system.
5. Gas Turbine topping system.

---

## 7.16 ANSWER TO SAQS

---

### SAQ 1

1. Cogen is an efficient way of producing electricity & heat. Traditional  
power generation waste a large portion of energy that is released by fuel  
combustion. Energy losses typically occur via exhaust, through the steam  
condensing system, and out of various cooling.  
Cogen unit recover heat from those loss streams and put that heat to good  
use. This is typically by providing heat or HW for use.  
Installing it can reduce CO<sub>2</sub> footprint of unit, enhance the reliability of its  
electric supply, and save money. More broadly, it's wide adoption provides  
benefit to adjacent users. These benefits are enhancing their energy security  
and making its energy infrastructure more resilient.
2. Cogeneration is a very efficient technology to generate electricity and heat.  
It is also called Combined Heat and Power (CHP) as cogeneration produces  
heat and electricity simultaneously.
3. Main reasons to use CHP are to save energy/ costs by reducing fuel  
consumption. For instance, in the advanced countries, users of CHP save  
about 15-20%  
With CHP, mech./ electrical energy produced, the bulk of the heat that's  
released isn't wasted. Less fuel is needed to generate the same amount of  
useful work that a conventional plant would produce.
  - Reduced fuel use has benefits, including: Lower of fuel /storage;  
and transportation;

- Reduced emissions CHP is most cost-effective ways to reduce CO<sub>2</sub>; and Less due to reduced pollutant exposure.
  - Another benefit is security.
4. Cogeneration can significantly reduce carbon emissions and energy costs, as the case studies show. The efficiency of combustion systems of a typical conventional power plant is about 40-50%, whereas the cogeneration systems that combine the power and heat generation processes can be up to 80% efficient.
  5. When a power plant generates electricity, it produces heat. If plant releases heat into the environment as exhaust, it represents a WH. When that repurposing of WH occurs, the plant is working as a Cogen.

The cogeneration can increase  $\eta_{ov}$ , with typical systems ranging from 65-90%. Businesses that use Cogen can lower operational costs and boost their self-sufficiency while reducing GHG emissions and pollutants.

6. There are four types of Cogeneration power plant technologies being used to generate power and steam: Combined Cycle CHP Plant; Steam Turbine CHP Plant; Internal Combustion Engine and Gas Turbine.
7. Cogeneration or combined heat and power (CHP) is the use of a heat engine or power station to generate electricity and useful heat at the same time.

## SAQ 2

1. In electric power transmission, wheeling is the transportation of electric energy (megawatt-hours) from within an electrical grid to an electrical load outside the grid boundaries.
2. In a topping cycle, the fuel supplied is used to first produce power and then thermal energy, which is the by-product of the cycle and is used to satisfy process heat or other thermal requirements in the plant. Topping cycle cogeneration is widely used and is the most popular method of cogeneration.
3. Bottoming cycle plants are much less common than topping cycle plants. In the bottoming cycle, the fuel is burnt in a furnace to produce synthetic rutile. The waste gases coming out of the furnace is utilised in a boiler to generate steam, which drives the turbine to produce electricity.
4. The heat-to-power ratio of a facility should match with the characteristics of the cogeneration system to be installed. It is defined as the ratio of thermal energy to electricity required by the energy consuming facility.
5. In simple terms, a steam turbine works by using a heat source (gas, coal, nuclear, solar) to heat water to extremely high temperatures until it is converted into steam. As that steam flows past a turbine's spinning blades, the steam expands and cools.
6. As hot combustion gas expands through the turbine, it spins the rotating blades. The rotating blades perform a dual function: they drive the compressor to draw more pressurized air into the combustion section, and they spin a generator to produce electricity.

7. Heat rate is one measure of the efficiency of electrical generators/power plants that convert a fuel into heat and into electricity. The heat rate is the amount of energy used by an electrical generator/power plant to generate one kilowatthour (kWh) of electricity.

---

## **7.16 REFERENCES and FURTHER READINGS**

---

1. National Productivity Council (NPC), New Delhi report on “Assessing cogeneration potential in Indian Industries”.
2. George Polimeros, Industrial Press Inc., N.Y., “Energy Cogeneration Handbook”.
3. Wayne C. Turner, School of Industrial Engineering and Management, Oklahoma State University, USA, “Energy Management Handbook”, (2001).
4. K. Naghbhusan Raju, Atlantic Publishers Ltd., “Industrial Energy Conservation Techniques”, (2007).
5. NIFES, UK, “Cogeneration - Training Material”.
6. George Polimeros, Industrial Press Inc., N.Y., “Energy Cogeneration handbook Criteria for Central Plant Designing”.
7. Variny, M., Mierka, O., “Technologic, economic and exergoeconomic evaluation of proposed industrial heat and power plant revamp in an industrial company in Slovakia”, Energy 36, 424-437 (2011).
8. User’s Manual, Version 3.1, Commonwealth Department of Industry, Tourism, and Resources, Commonwealth of Australia, “Cogeneration Ready Reckoner” September 2002.
9. Office of Environment and Heritage NSW, 59 Goulburn Street, Sydney NSW 2000, Australia, ISBN 9781 74359 2380, OEH 2014/0685, “Energy Saver Cogeneration Feasibility Guide”, Sept. 2014.
10. Aspen Systems Corp. for the U.S. Department of Energy, Washington, D.C., “Combined Heat and Power: A Federal Manager’s Resource Guide”, March 2000.
11. DOE/NBB-0057, prepared by Pacific Northwest National Laboratory for the U.S. Department of Energy, Washington, D.C., “Cogeneration Handbook for the Pulp and Paper Industry”, February 1984.
12. DOE/NBB-0058, prepared by Pacific Northwest National Laboratory for the U.S. Department of Energy, Washington, D.C., “Cogeneration Handbook for the Textile Industry”, February 1984.
13. DFIC - Dr. Fromme International Consulting, published by Deutsche Gesellschaft für Internationale Zusammenarbeit (GIZ) GmbH: "Cogeneration & Trigeneration - How to Produce Energy Efficiently", Eschborn, Germany, 2016.
14. International Energy Agency, “Net Zero by 2050: A Roadmap for the Global Energy Sector”, Oct., 2021.
15. Proceedings of Conference “COGEN INDIA 96”, held on 10/11 March 1996.
16. Bureau of Energy Efficiency, New Delhi, “Cogeneration, Chapter 7, Energy Efficiency in Thermal utilities, Guide Book 2”.

17. Bureau of Energy Efficiency, New Delhi, “Cogeneration, Turbines (Gas, Steam), Chapter 3 Energy Efficiency in Thermal utilities, Guide Book 4”.

18. Bureau of Energy Efficiency, New Delhi, “Energy Performance Assessment of Cogeneration and Turbines (Gas, Steam), Chapter 3 Energy Efficiency in Thermal utilities, Guide Book 4”.

19. Bureau of Energy Efficiency, New Delhi; Indian Renewable Energy Development Agency, New Delhi; and Devki Energy Consultancy Pvt. Ltd., Vadodara, “Best Practice Manual – Cogeneration”, 2006.



ignou  
THE PEOPLE'S  
UNIVERSITY



**ignou**  
THE PEOPLE'S  
UNIVERSITY